

Thinking through population-based genetic screening for cancer:

The example of *BRCA1* and *BRCA2*

Hormuzd A. Katki, Ph.D.

Senior Investigator

Division of Cancer Epidemiology and Genetics

Should we screen for mutations?

- **The ACMG recommends that 67 germline genetic mutations should be reported to patients if incidentally found**
 - Cause high risk of disease
 - Risk-reducing measures exist (if sometimes drastic)
 - Fortunately each mutation is generally rare
 - Sometimes not so rare in special populations
- **Question: Should we screen general populations for these mutations?**
 - **Meaning: Should we test healthy individuals with minimal or no family history of the disease in question?**

BRCA1 and BRCA2

- **Mutations confer very high lifetime cancer risks**
 - 40% to 70% lifetime breast cancer risk
 - 10% to 40% lifetime ovarian cancer risk
- **Pathogenic mutations are rare (0.25%; 1 in 400)**
 - Except in Ashkenazi Jews: 2.5% or 1 in 40
- **Mutation carriers have risk-reducing options**
 - Oophorectomy and/or mastectomy
 - Not all women choose those drastic options

The genie is out of the bottle: The FDA now allows direct-to-consumer genetic testing

- Last month, the FDA allowed 23andMe to test for the 3 *BRCA1/2* mutations most common in Ashkenazi-Jews
 - For the first time in history, direct-to-consumer genetic testing for medical conditions has been approved.
- Researchers and doctors warn
 - Not having these mutations does not mean you have no *BRCA1/2* mutation
 - Especially if you're not Jewish!
 - There are other cancer genes, not just *BRCA1/2*.
 - Even if you have no known mutation, your family history still may predispose you to cancer
- You need qualified medical advice to make decisions
 - Follow-up testing or risk-reducing interventions

Who is currently getting tested for *BRCA1/2* mutations?

c) Carrier-Probability 2.3%

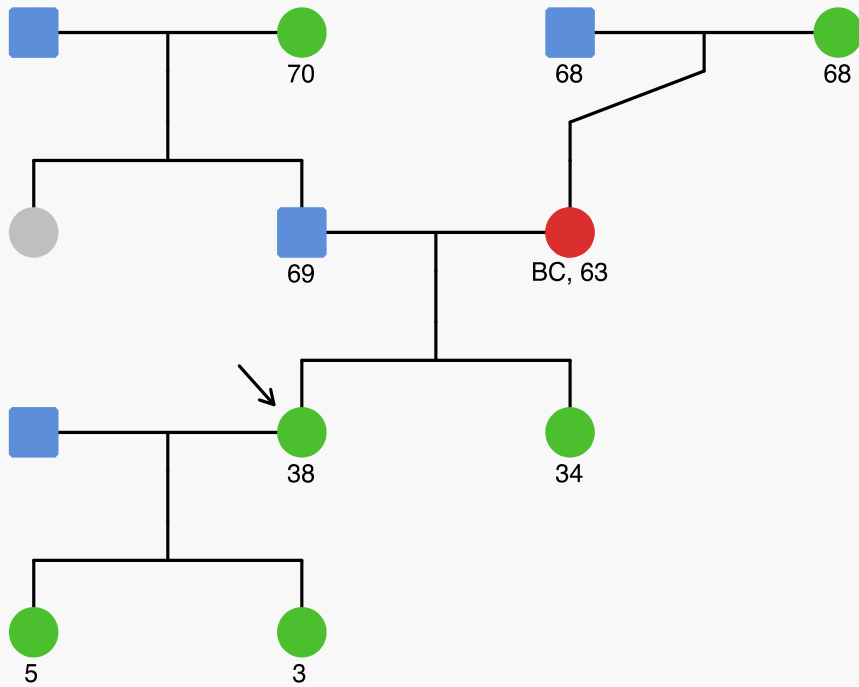

- Currently women must meet established testing guidelines, necessary for insurance coverage
 - Requires strong family history of breast or ovarian cancer: “10%” chance of harboring a mutation
- NCCN guidelines allow most Ashkenazi Jewish women with family history to get tested
- To date
 - Fewer than 15% of US BRCA1/2 mutation-carriers have been identified
 - Fewer than 1 in 5 women eligible for testing by NCCN guidelines have been tested

Prominent voices call for testing everyone



- Genetic testing costs have plummeted
 - 23andMe: \$199!
 - Even full sequencing is now <\$1000
- Should we test everyone?
 - Or at least all Ashkenazim?
 - 50% of BRCA mutations carriers have no “clinically significant” family history
 - May be cost-effective
- Others counter
 - Even at 10% risk, we have a backlog
 - Only 4,140 genetic counsellors are certified
 - Variants of Uncertain Significance are common
 - Testing millions of women will cost many billions of dollars

A Modest Proposal: Choose a risk-threshold between 10% and test everyone (0%)

- **No cost-effectiveness analysis has been done to justify a carrier-probability threshold**
 - 10% is rule-of-thumb
 - Test everyone means a 0% carrier-probability threshold
- **What about thresholds between 0%-10%?**
 - Can we identify 80%-90% of BRCA mutation carriers while avoiding testing for many obviously mutation-negative women?

Washington Ashkenazi Study (WAS)

- **We calculated carrier probability using the BRCAPRO statistical model, for 4589 volunteers in WAS**
 - 102 BRCA1/2 founder mutations
- **At different carrier-probability thresholds**
 - % of mutation-carriers identified
 - % of population requiring testing
- **If we should NOT test all Ashkenazim, then we certainly should NOT test the entire general population**

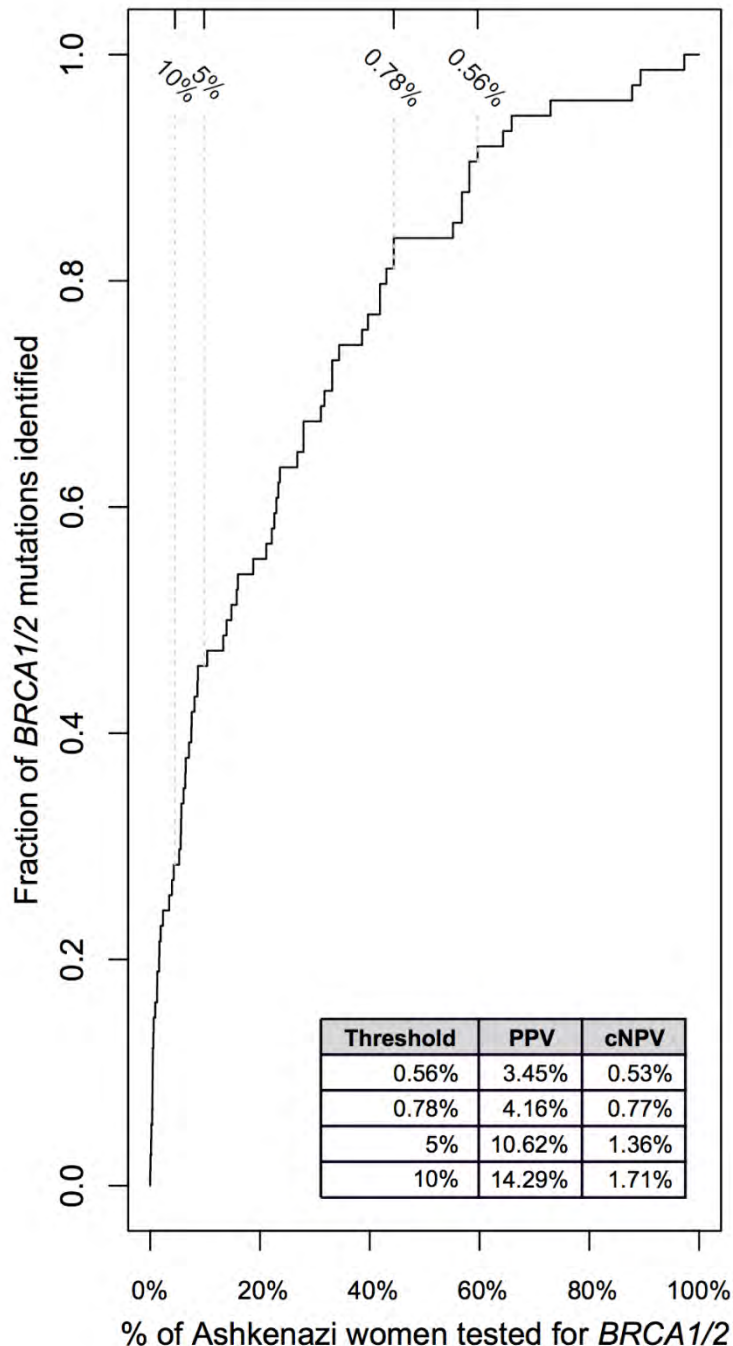

Don't need to test everyone

- 90% of founder mutation carriers found in 60% of Ashkenazi women
 - Carrier-probability > 0.56%
- 10% carrier-probability identifies only 28% of founder mutation carriers
- Wide range of choices for choosing a cost-effective carrier-probability threshold
 - E.g. 80% of founder mutations found by testing 44% of Ashkenazi women
 - Carrier-probability > 0.78%

The Future: Multigene Panel Tests

- **Multigene panels are necessary when**
 - The syndrome is unclear
 - Multiple genes might explain the phenotype
 - Single-gene testing fails to detect a pathogenic germline mutation
- **Multigene panel costs are plummeting**
- **In a study of 50,726 members of the Geisinger Health System, 3.5% carried a clinically actionable mutation**

More challenges in genetic screening with multigene panel tests

- **Risk estimates for mutations are from families with strong history of the disease**
- **But population screening will test people with minimal or no family history of the disease**
- **Many, perhaps most, people who carry the mutation will have no family history in the disease spectrum of the mutation**
 - **Do they really have the same very high risk of disease as do those from heavily loaded families?**

Most people who carry a mutation may have no family history of the disease it causes

- Mutations in *TP53* cause high risk of many cancers
 - 1 in 500 people may carry such mutations
- Mutations in *DICER1* cause childhood pleuropulmonary blastomas
 - 1 in 10,000 children may carry such mutations
- Compared to those whose *TP53* mutation was found by single-gene testing
 - Those whose *TP53* mutation was found by a multigene panel had up to 25 years later onset of cancer

Risk assessment from mutation test results: Family history still matters

- ***BRCA1/2* mutation carriers have 1.5-fold higher breast cancer risks if any relatives have breast cancer**
 - *BRCA1/2* mutation carriers have 25 percentage points fewer lifetime breast cancers if no relatives have breast cancer
- **The effect of rare, highly-penetrant susceptibility gene mutations can be greatly amplified, or muted, by even weak personal/family cancer history and other non-genetic risk factors**

Summary of challenges in population screening using multigene panels

- Many people (~3.5%) may test positive
- Many, if not most, of them will have no family history in the spectrum of disease
- They cannot be advised they have the same disease risks as those from heavily loaded families
- Considering personal/family cancer history and other risk factors will be paramount, because risk factors are magnified in the presence of powerful mutations
- We may inaccurately counsel many, perhaps even most, people with mutations found by multigene-panel testing by population screening

Possible roles of advocates in population genetic screening

- **Direct-to-consumer may seem empowering, but may actually be dangerous**
 - **Direct-to-consumer places cost burden on patients**
 - **Exacerbate health inequalities**
- **Reduce stigmatization of special populations**
- **Help recruit populations into screening**
- **Publicize that genetic test results must be interpreted with the help of trained clinicians**
- **Need to increase confidentiality of genetic test results**
 - **Genetic Information Nondiscrimination Act (GINA) does not cover life insurance**